

# INSTALLATION GUIDE

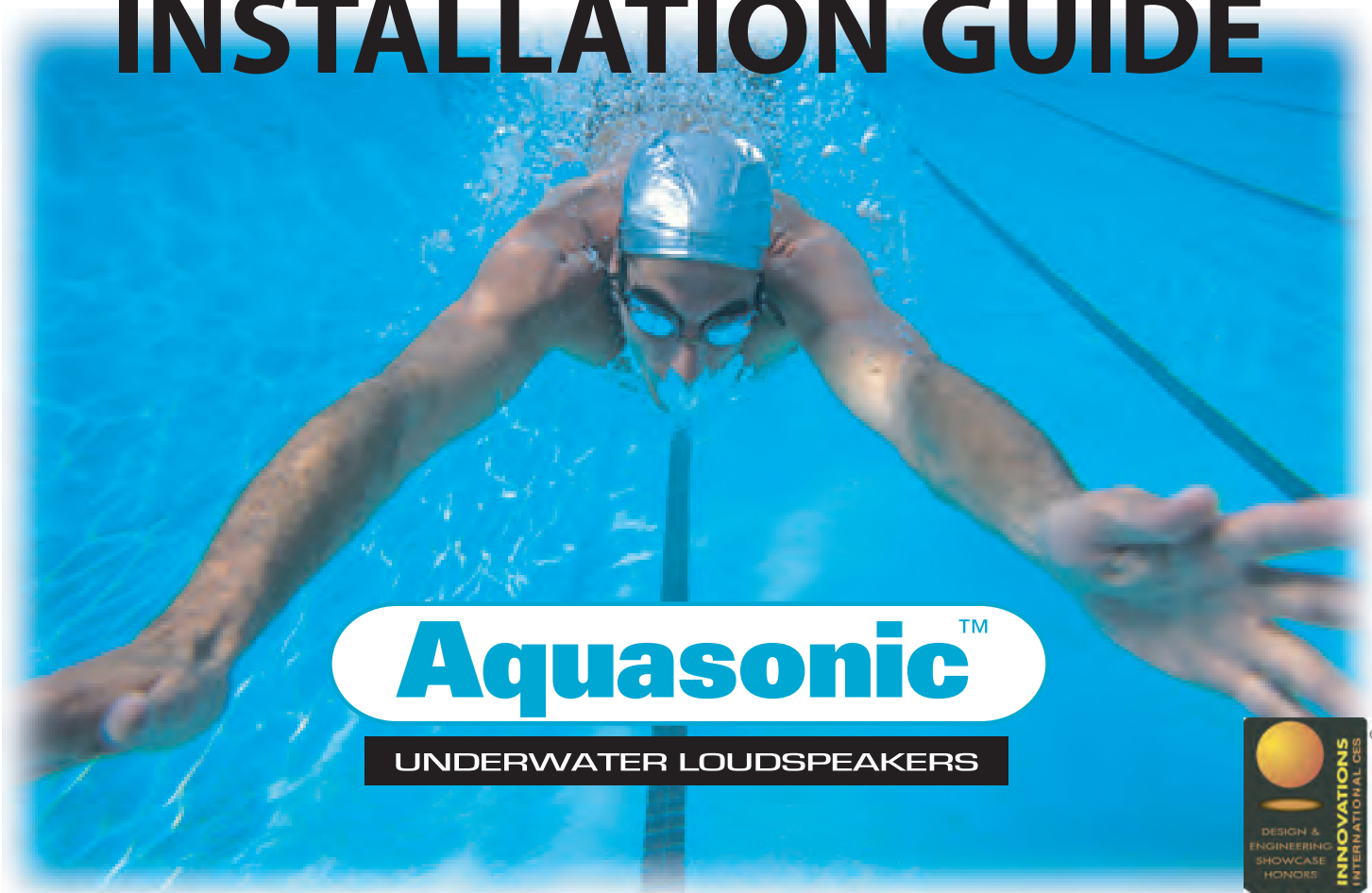

**Aquasonic™**

**UNDERWATER LOUDSPEAKERS**



Aquasonic® Awarded the Design and Engineering Award at 2004 International CES

## Aquasonic® AC339 Easily Converts To One Of the Following Configurations



Portable Floating Model



In-Wall Model



Portable Drop-In Model





# GENERAL SAFETY INSTRUCTIONS

Thank you for purchasing the Aquasonic® AC339 from Clark Synthesis Tactile Sound. Please read the following instructions before assembling and using the product.

---

1. **DO NOT DROP SPEAKER** - If damage occurs due to high impact of speaker, it is not covered under warranty.
2. **Do not expose speaker to high distortion levels** - Excess distortion may result in failure. If speaker shuts down the built-in protection circuit is signaling that the volume level is too high. Turn the amplifier off for approximately 45 - 90 seconds to allow the TST to reset. Operate at reduced volume. Continued use of high levels of distortion may fail speaker, which is not covered under warranty.
3. **Use a ground fault interrupter** - A GFI outlet or extension cable on the stereo system will prevent electrical shock in the event of a malfunction. These are available at hardware stores or home improvement stores. They are easy to install and provide a safe operating environment for your electronics and all pool users.
4. **Place speaker in pool away from diving boards and high activity areas** - Severe injury may result if speaker is contacted while diving or jumping.
5. **Cable placement** - Do not place cable in high traffic areas where people may trip or cable may tangle causing possible drowning or where pets may damage cable.
6. **Do not hang speaker by speaker cable** - Use a tether (nylon rope) tied to the eyelet on the speaker, and tie other end to a stationary anchor.
7. **Do not drag speaker on pool deck, bottom or side of pool** - This will damage speaker and is not covered under warranty.
8. **Do not remove or alter the watertight fitting from speaker housing** - This fitting is set at the factory to seal out water. Over tightening may destroy the water-tight seal. Any physical alteration or damage will void the warranty.
9. **Avoid Excessive heat** - Do not leave speaker in direct sunlight unless submerged in pool. High temperatures, as in a closed car, may result in damage and will void the warranty.
10. **The built-in protection circuit** - If the speaker shuts down, turn the amplifier off for approximately 45 - 90 seconds to allow the speaker to reset. Restart the amplifier at a lower volume. The protection circuit is triggered by excessive heat, distortion, or being overpowered. Continued overload of shut down circuit or abuse without correction of system may fail speaker, which is not covered under warranty. If symptoms persist the system may need to be configured differently. Contact Clark Synthesis or local dealer for assistance.

# INDEX OF CONFIGURATIONS

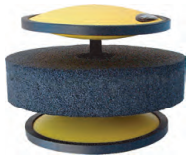

Portable Floating Model  
Page 2



In-Wall Model  
(Shown with Third-Party Light Niche)  
Page 3



Portable Drop-In Model  
Page 5

## SUPPLIED/REQUIRED ITEMS

### Supplied Parts

- A. (1 ea.) Tactile Sound Transducer - Below Water TST
- B. (1 ea.) Acoustic Sound Lens - ASL
- C. (3 ea.) Jam Nut
- D. (1 ea.) Stainless Steel Stud
- E. (2 ea.) Stainless Steel Washers
- F. (1 ea.) Passive Transducer - Above Water
- G. (1 ea.) Float
- H. (8 ea.) Wire Floats
  - 100' Underwater Speaker Wire Cable
  - Installation Guide

### Required Tools and Materials

- Third-Party Light Niche Part
- #2 Phillips Screwdriver
- (2 ea.) 9/16" Open-Ended Wrenches

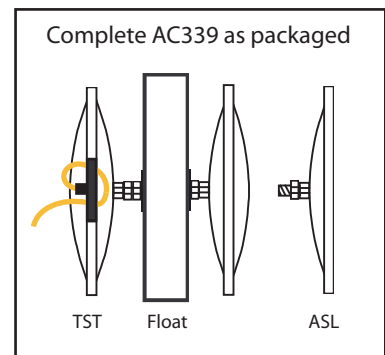

**Carefully unpack product. DO NOT discard any parts or packaging until installation is complete.**

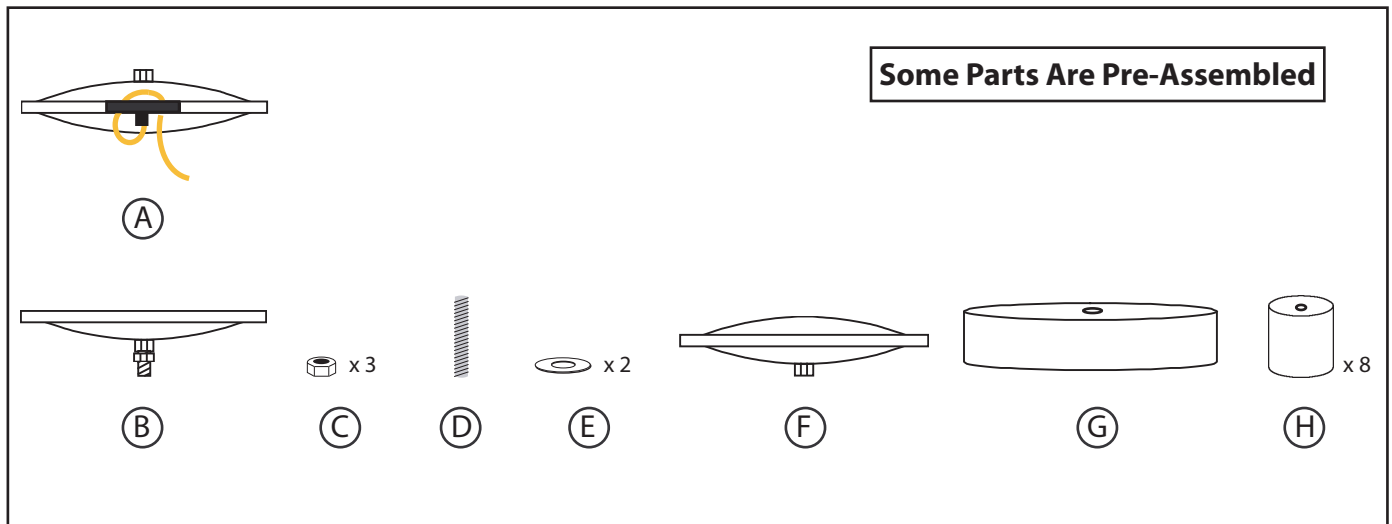

### Required Audio Components

- Power: Receiver or amplifier for the TST. All AC339 configurations should be powered with between 100watts and 200watts. Make sure your amplifier is capable of driving a 4-ohm load.

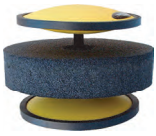

# AQUASONIC FLOATING INSTALLATION

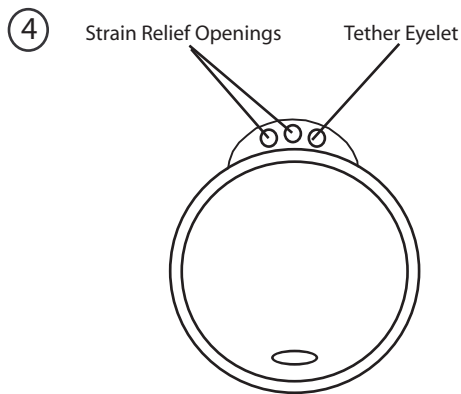

1. Remove speaker from packaging.
2. Remove 8-wire floats from top of styrofoam packing.
3. Slide wire floats (8) onto speaker wire, as needed.
4. Attach optional nylon rope of desired length to tether eyelet hole in rubber ring flange. Tether/nylon rope can be purchased at pool supply or hardware store.
5. Hook up to stereo (100 - 200 watts recommended).
6. Enjoy!

★ If speaker shuts off, turn off for approximately 45 seconds to allow internal protection circuit to reset. Turn down volume.

★ Use same underwater cable with waterproof connector to extend cable—extra cable available from Clark Synthesis.

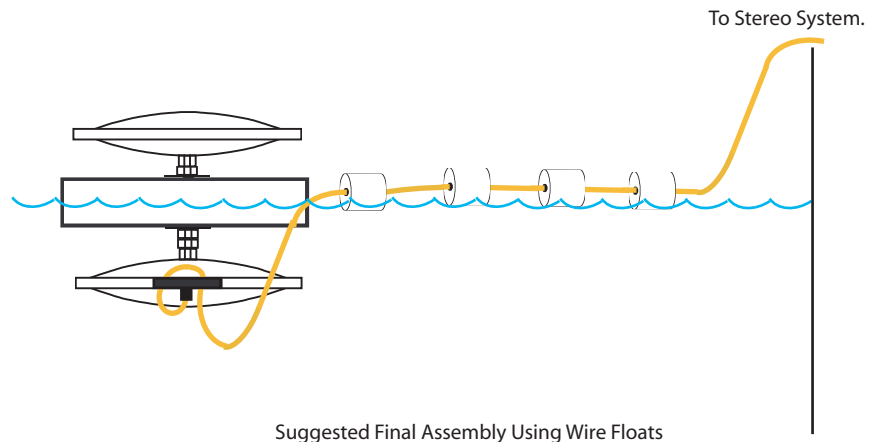





# AQUASONIC IN-WALL INSTALLATION

This configuration requires some assembly. The Aquasonic® AC339 simply replaces the light bulb in the light niche.

**TOOLS NEEDED:** Phillips Head Screwdriver, 2-9/16" Open-Ended Wrenches.

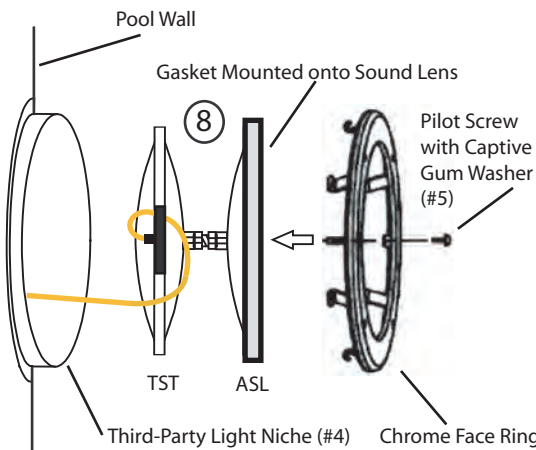
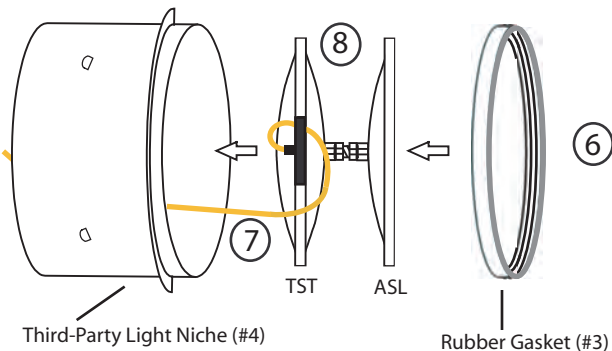
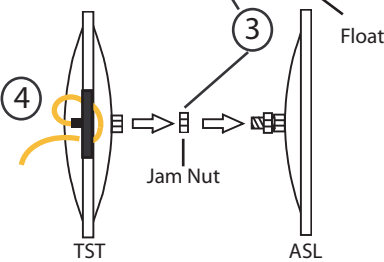
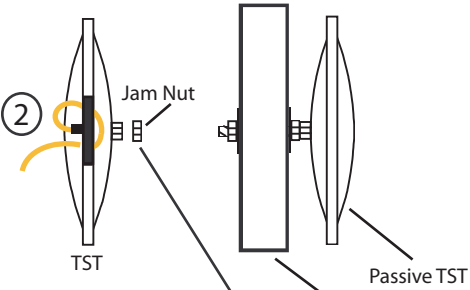
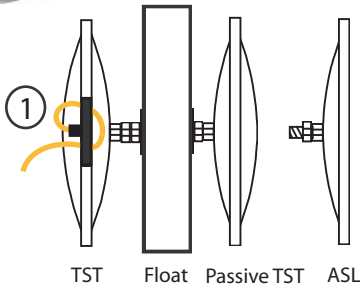

1. Remove AC339 and acoustic sound lens (ASL) from packaging.
2. Separate the TST from the float. Using the 9/16" wrenches, loosen the jam nut to remove the float assembly from the gold mounting point on the TST. Use one 9/16" wrench to hold the TST's gold fastener, and with the second 9/16" wrench turn the jam nut away from the gold mounting point until float and TST are separated.
3. Remove one jam nut from the threaded stud on float assembly. Thread jam nut completely onto stud attached to acoustic sound lens. You should now have two jam nuts threaded completely on to the stud connected to the sound lens.
4. Fully thread acoustic sound lens onto TST. Using two wrenches tighten jam nut against the mounting point. Using one wrench to hold the TST's gold fastener, while the second tightens the jam nut against the gold mounting point. Make sure that jam nut is firmly tightened against the gold mounting point. This assembly is now ready for installing into a third-party light niche.

**IMPORTANT NOTE: DO NOT ASSEMBLE BY USING THE DOME ITSELF TO TIGHTEN—MAKE SURE TO TIGHTEN THE TSTs BY USING A 9/16" WRENCH ON THE GOLD HEX MOUNTING POINT AND TURN THE JAM NUT USING A SECOND 9/16" WRENCH.**

*Please refer to page 5 for exploded diagram and part listing.*

5. Remove rubber gasket (#3) from a third-party light niche face ring assembly (#1) by loosening Phillips head screw on unitension wire clamp (#2).
6. Wrap rubber gasket (#3) onto acoustic lens black rubber ring then re-install (#3) with AC339 assembly installed into face ring (#1). Tighten unitension wire clamp (#2).
7. Insert finished end of underwater speaker cable into conduit opening in back of light niche (#4). Thread wire through conduit to junction box.
8. Insert complete assembly into light niche back can (#4) using pilot screw with captive gum washer (#5) to fasten chrome face ring assembly (#1) to finish installation.
9. Connect supplied speaker wire to sound system amplifier by connecting the red insulated wire to the positive terminal and the black insulated wire to the negative terminal.
10. Adjust volume level—enjoy!



# IN-WALL ASSEMBLY PARTS LIST

## Parts Supplied By Third Party

Item #	Part No.	Description
1	79110600	Face ring assembly, stainless steel
2	79111000	Unitension wire clamp assembly
3	79101600	Gasket for 8-3/8" lens
4	00782105	Light niche
5	79104800	Pilot screw with captive gum washer

## Parts Supplied By Clark Synthesis/Aquasonic

Item #	Part No.	Clark Synthesis/Aquasonic Description
A	AC339	Aquasonic underwater speaker (TST)
B	ASL339	Clark Synthesis acoustic sound lens
C	LN002	Lock nut (2)
D	SS-015	Stainless steel stud

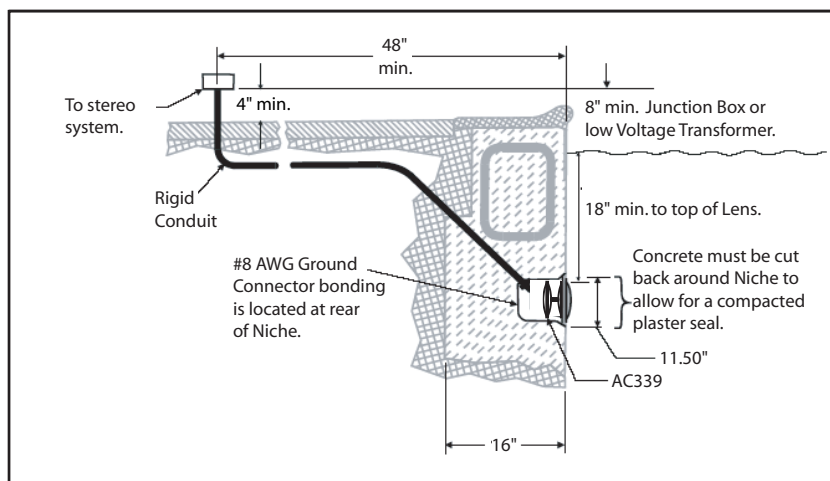
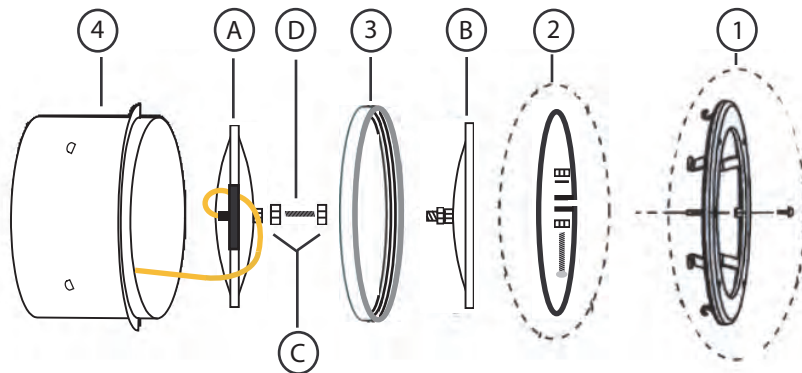



# AQUASONIC DROP-IN INSTALLATION

This configuration requires some assembly. A tether is recommended to suspend speaker in water.

**TOOLS NEEDED:** Phillips Head Screwdriver, 2-9/16" Open-Ended Wrenches.

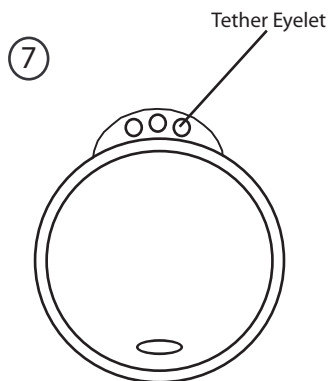
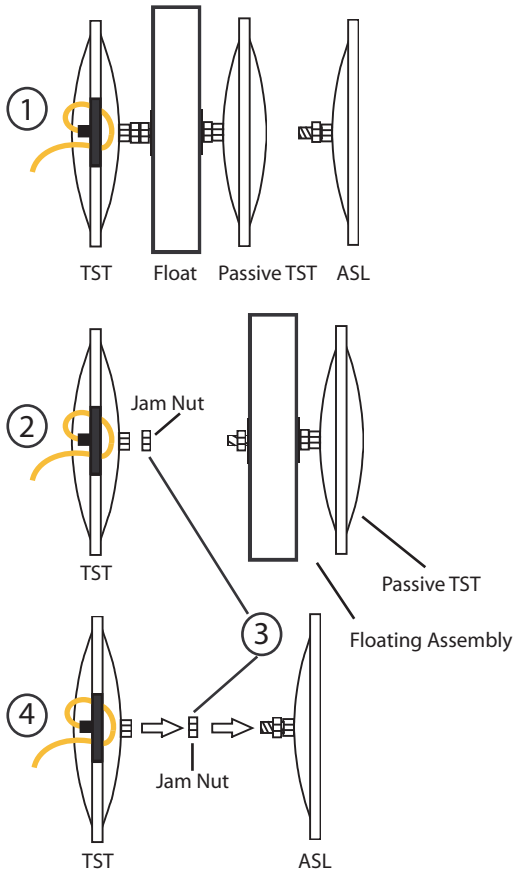

1. Remove AC339 and acoustic sound lens (ASL) from packaging.
2. Separate the TST from the float. Using the 9/16" wrenches, loosen the jam nut to remove the float assembly from the gold mounting point on the TST. Use one 9/16" wrench to hold the TST's gold fastener, and with the second 9/16" wrench turn the jam nut away from the gold mounting point until float and TST are separated.
3. Remove one jam nut from the threaded stud on float assembly. Thread jam nut completely onto stud attached to acoustic sound lens. You should now have two jam nuts threaded completely on to the stud connected to the sound lens.
4. Fully thread acoustic sound lens onto TST. Using two wrenches tighten jam nut against the mounting point. Using one wrench to hold the TST's gold fastener, while the second tightens the jam nut against the gold mounting point. Make sure that jam nut is firmly tightened against the gold mounting point. This assembly is now ready to have a tether attached and be lowered into water.

**IMPORTANT NOTE: DO NOT ASSEMBLE BY USING THE DOME ITSELF TO TIGHTEN—MAKE SURE TO TIGHTEN THE TSTs BY USING A 9/16" WRENCH ON THE GOLD HEX MOUNTING POINT AND TURN THE JAM NUT USING A SECOND 9/16" WRENCH.**

7. Attach nylon rope\* (not supplied) to tether eyelet.
8. Use wire floats (H) as needed.
9. Connect speaker wires to sound system.
10. Unit is ready to be dropped into water.
11. Adjust volume.
12. Enjoy!

\* Recommended option: A tether (nylon rope) is recommended to use to raise, lower, and suspend speaker in water—this can be purchased at your local hardware or pool supply store.

**\*\* Quick Connect Kit on Page 7**

# CLARK SYNTHESIS' FULL PRODUCT LINE



TST429-Platinum

**TST429-Platinum**—Most powerful Tactile Sound Transducer in the world. Can be installed in home theater seating, risers, and subfloors.



TST329-Gold

**TST329-Gold**—Used in flight and warfare simulators since 1993, and thrilled millions at major amusement and theme resort parks.



TST239-Silver

**TST239-Silver**—More powerful beginning of our superior line up. Perfect for home theater seating, and gaming.



AW339-All Weather

**AW339-All Weather**—First and only Tactile Sound Transducer built specifically for decks, boat hulls, docks. Transducer is weather-proof for harsh, damp, or wet environments.



## *Over Ten Years of Innovation!*

As the leaders in Tactile Technology we have been honored with the Innovations Design and Engineering Award for the TST 329 in 1998, the Sensation Theater Seat in 2002, and the AC339 in 2004.

# CLARK SYNTHESIS' ACCESSORIES

Clark Synthesis Tactile Sound has many accessories in development to aid in installations of the AC339-Aquasonic Underwater Speaker. For a complete list of accessories please contact us at:

Clark Synthesis Corp.  
12905 Division Street, Suite B  
Littleton, CO 8012  
TEL: 303-797-7500  
FAX: 303-797-7501  
<http://clarksynthesis.com/>



Celebrating Ten Years as "the movers and shakers in the industry." Clark Synthesis Corporation has been breathing life-like reality into flight and warfare simulators since 1993, and thrilled millions at major amusement and theme resort parks. Clark Synthesis Tactile Sound re-invented the home theater, combining the thrill of a theme park ride with the mil-spec accuracy of flight simulators. Musicians worldwide are saving their hearing and improving their sound by using Tactile Monitors onstage and in the studio. Clark Synthesis is committed to bringing the best Tactile Sound experience to the military, educators, medical researchers, performing musicians, creative professionals, and consumers around the world through its innovative Tactile Sound Transducers and its many applications of "Full Contact Audio" technology.



**Aquasonic® Awarded the Design and Engineering Award at 2004 International CES**



## WARRANTY

### One-Year Limited Warranty

Your AC339-Aquasonic Sound Series Underwater Speaker is a quality crafted device made to give many years of high performance. Each speaker is guaranteed for 1 year from date of purchase on material and workmanship. Clark Synthesis Corp. will repair or replace at our sole discretion. Warranty void if TST is altered, modified, abused or tampered with in any way. Do not attempt to disassemble or repair the Tactile Sound Transducer yourself. Take it to an authorized service facility or return to the manufacturer for repair or replacement.

Copy of dated proof of purchase/invoice is required for warranty claim. This is the responsibility of the purchaser.

For service/warranty in USA return call for and RAN (Return Authorization Number). **Write RAN clearly on outside of box.** Without this properly displayed on the outside of the box, the package will be refused. For tracking purposes we strongly suggest that you use a carrier such as Federal Express, UPS, or DHL.

Pack the product in its original packing and return to:

Clark Synthesis Corp.  
12905 Division Street, Suite B  
Littleton, CO 80125  
TEL: 303-797-7500  
FAX: 303-797-7501  
info@clarksynthesis.com